



TEKTRONIX®

committed to
technical excellence

data sheet

PARTS PUBLICATION

P6302 CURRENT PROBE

010-6302-01

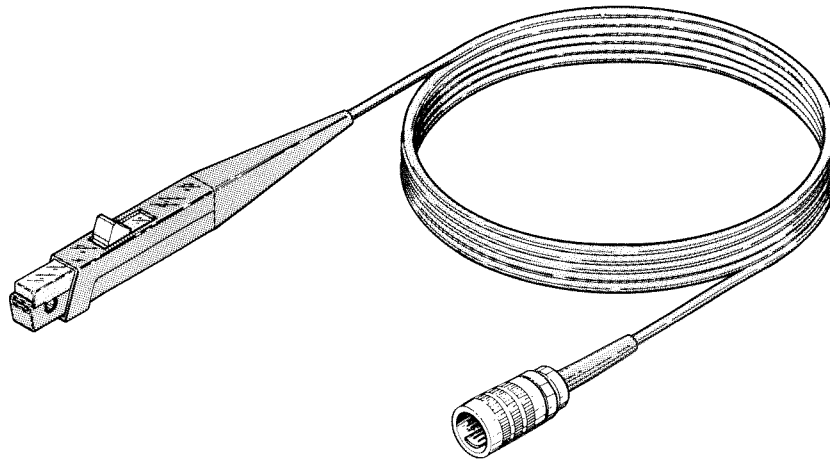

The P6302 is a dc to 50 MHz probe capable of measuring currents to 20 A dc (or dc plus peak ac), and up to 50 A peak current, not to exceed the amp-second rating. The P6302 is designed for use with the AM 503 Current Probe Amplifier.

A Hall generator device is used in the probe to provide dc and low-frequency current information. Low-frequency (from the Hall device) and high-frequency (from the current transformer) information are combined in the AM 503 to produce an accurate representation of the current being measured.

A spring-loaded slider permits the current transformer core to open and close around a conductor. The slider is pushed forward into the CLOSED position to measure the current in a conductor. A multi-pin connector is provided to permit the operator to disconnect the probe from the AM 503.

NO. 062-2322-00
DATE Oct. 1976 (R)

COPYRIGHT © 1976
TEKTRONIX, INC.
ALL RIGHTS RESERVED

SPECIFICATION

The performance limits in the specification apply only when used with the AM 503 Current Probe Amplifier, after a 20-minute warmup.

Electrical

Maximum Input Current

DC + Peak AC: 20 A (see current vs. frequency derating curves, Fig. 1).

Peak Pulse: 50 A (do not exceed 100×10^{-6} , amp-second product).

Maximum Voltage

Bare Conductor Under Test: 500 V (dc + peak ac).

NOTE

Do not let the probe transformer core touch the bare conductor under test. The core is not insulated.

Random Noise

0.3 mA or less (measured tangentially) with AM 503 BANDWIDTH set to 5 MHz.

Bandwidth (–3 dB)

AM 503 BANDWIDTH set to FULL: DC to at least 50 MHz.

Insertion Impedance

See Fig. 2.

Environmental

Temperature

Operating: 0° to +50° C.

Altitude

Operating: to 15,000 feet

Physical

Dimensions, Probe Head

Length: 7 7/8 inches

Height: 1 1/4 inches

Width: 7/16 inch

Jaw Size: 0.15 inch

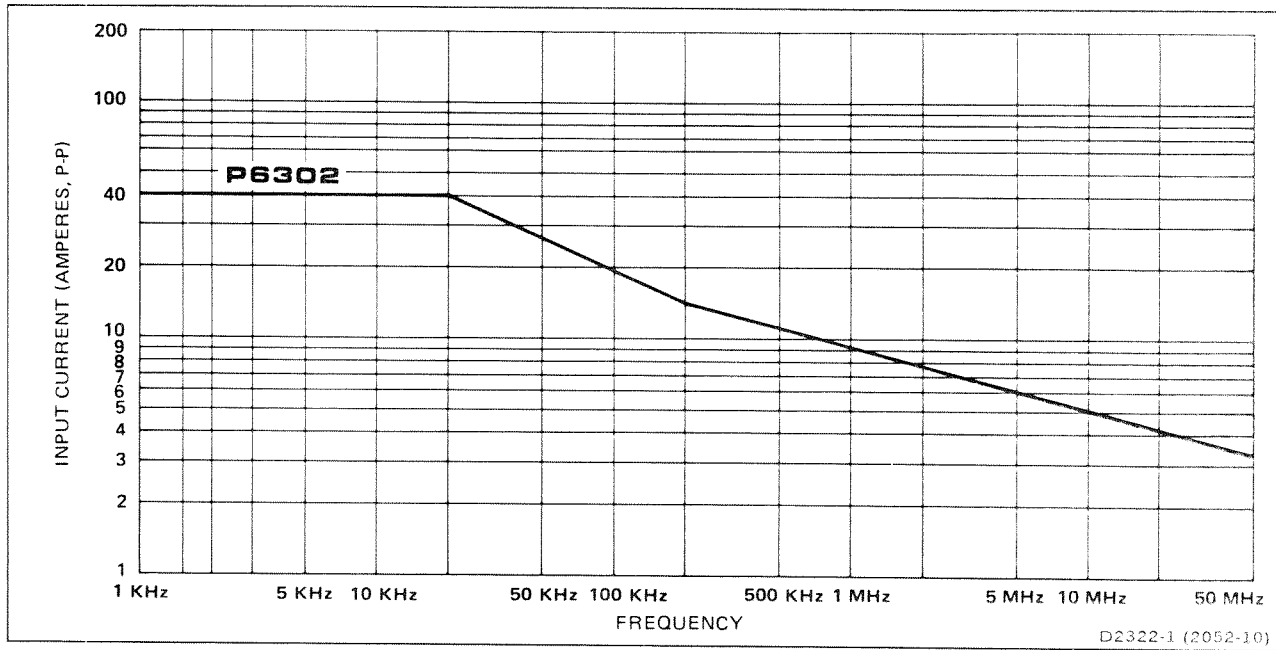

Fig. 1

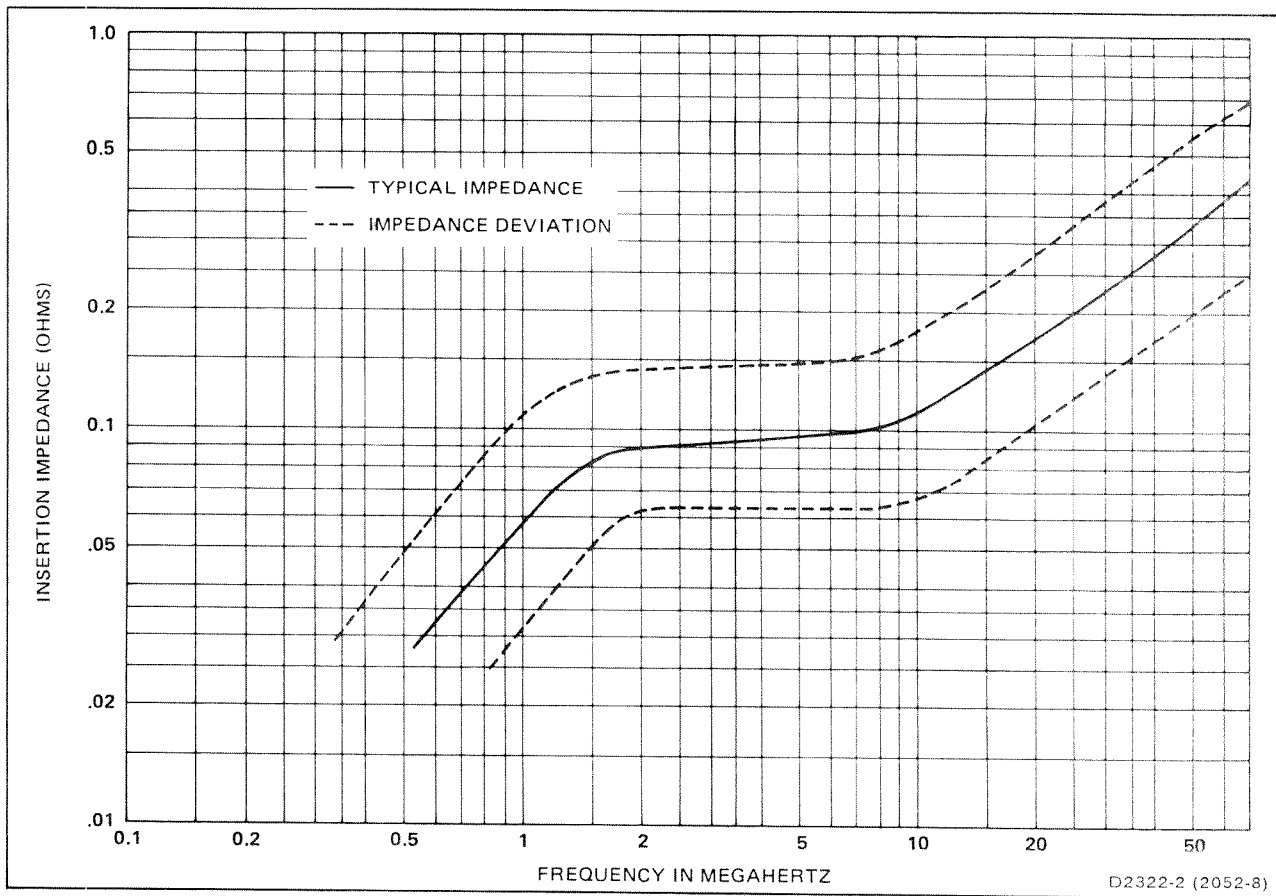

Fig. 2

OPERATING CONSIDERATIONS

Ground Clip Leads

Two ground-clip leads are supplied with each probe. These leads are provided to ground the probe shield at the probe head to reduce high-frequency electrostatic voltages that could be coupled to the current transformer. Normally, the ground lead is not used in the 1, 2, 5, and 10 mA positions of the AM 503 CURRENT/DIV switch due to undesirable currents that may appear in these more sensitive positions. When observing high-frequency signals, use the short ground lead.

Circuit Loading

To minimize loading of critical circuits, clamp the probe at the low or ground end of a component lead whenever possible.

NOTE

The P6302 Current Probe measures magnetic flux around a conductor, caused by current in the conductor. Keep this in mind when reading dc current in ferrous leads (such as transistor leads) that may be magnetized. This lead flux causes erroneous readings in the more sensitive AM 503 CURRENT/DIV settings.

Direction of Current Flow

To display correct polarity, the probe should be clamped around a conductor with the probe arrow pointing in the direction of conventional current flow (plus to minus).

MAINTENANCE

Cleaning (Outside Surfaces)

Use a soft-bristle brush to dislodge the dirt and dust, then wipe clean with a lint-free cloth. If a persistent coating of dirt remains, use a soft cloth dampened in a mild detergent and water solution. Do not use abrasive cleaners.

CAUTION

Avoid the use of chemical cleaning agents that might damage the plastics used in the probe. In particular, avoid chemicals that contain benzene, toluene, xylene, acetone, or similar solvents.

Recommended cleaning agents are isopropyl alcohol (isopropanol) or ethyl alcohol (Fotocol or ethanol).

Servicing

Only qualified service personnel should use the following service instructions.

The P6302 Current Probe is designed to withstand normal operation and handling. However, if the probe fails or breaks, replacement parts are available. See Replaceable Parts list for part numbers.

LUBRICATION. Do not lubricate the gap between the stationary and movable transformer core pieces. Any lubricant between the core pieces should be removed with a recommended cleaning agent.

Slide Switch. This switch is lubricated before leaving the factory. Should the switch become noisy, clean and lubricate with No Noise.

Movable Plastic Parts. Should the plastic slide assembly require lubrication, apply Versilube silicone grease sparingly to the plastic.

Probe Disassembly Procedure (See Fig. 3)

1. Move the probe slider assembly to the OPEN position.
2. Remove the two screws from the bottom of the probe body and pull the strain relief boot back on the cable.
3. While holding the probe in a horizontal position with the slide assembly up, lift the top half of the body and slide the top half off the end of the probe.

NOTE

Don't let the metal ball, in the top of the slide assembly, fall out. The ball may be easily lost.

4. Remove the metal ball.
5. Lift the spring retainer and spring out of the spring holder. Remove the spring and retainer (lift the back of the slide assembly).
6. Lay the probe on its side and remove the slide assembly. When removing the movable portion of the transformer core and the contact for the slide assembly, note the position of the contact spring. Switch contacts are not removable from the slide assembly.
7. Remove the spring holder from the bottom half of the probe body.
8. To remove the stationary transformer core, first lift out the transformer-circuit board assembly, then carefully grip the stationary transformer core and pull it out of its socket. If necessary, unsolder the cable connection to the bottom half of the probe body.

Probe Assembly Procedure (See Fig. 3)

1. If unsoldered, resolder the cable connection to the bottom half of the probe body.
2. Plug the stationary transformer core into the 8-pin connector.
3. Place the circuit board and transformer core into the bottom half of the probe body and replace the spring holder.
4. Replace the contact spring and movable core in the slide assembly. Place the spring and spring retainer in the spring guide on the slide assembly.
5. With both halves of the probe body held upside down, insert the slide assembly tip into the slot at the front of the probe body and bring the two pieces together. Be sure that the slide assembly switch contacts go on the inside (toward the center) of the stationary contacts. As the two pieces are brought together, push the spring retainer into the spring holder.

6. Hold the probe with the slide assembly up and place the metal ball into the hole in the slide assembly.
7. Replace the top half of the probe body, the strain relief boot, and the two screws.

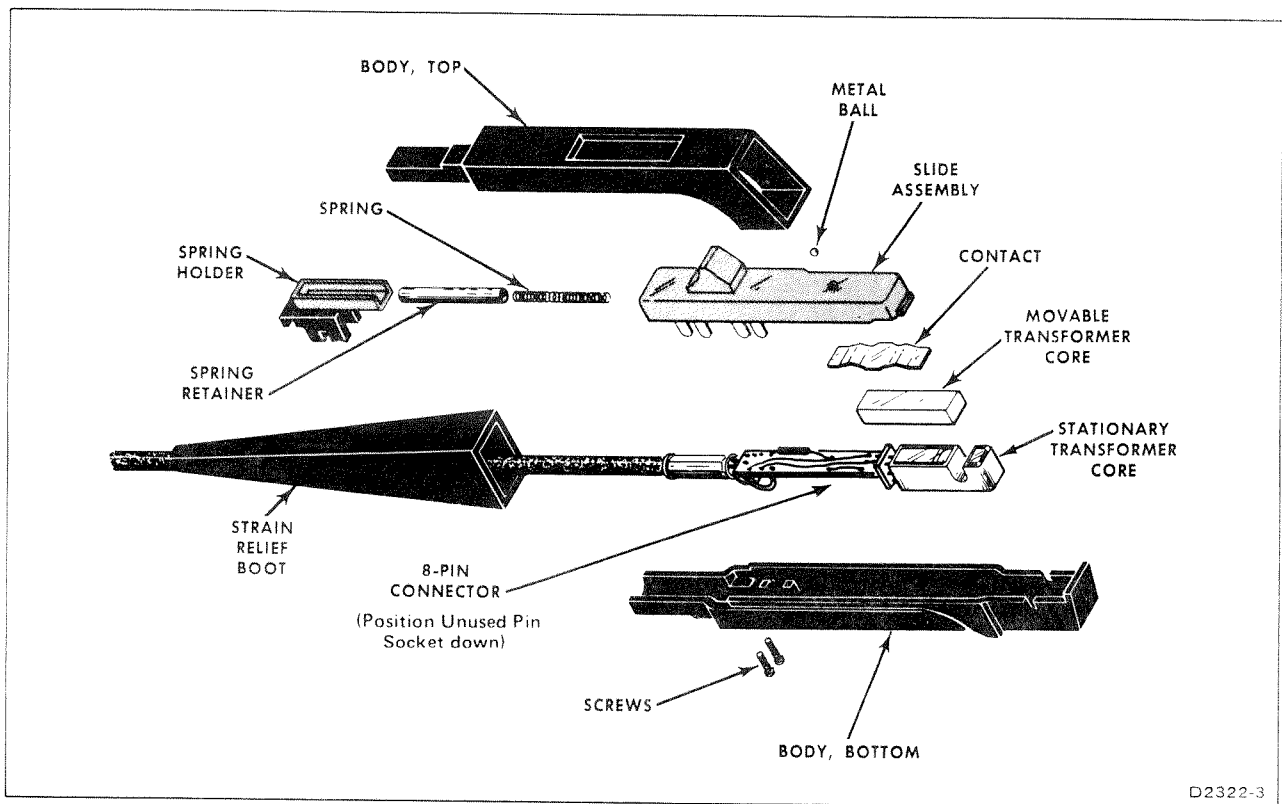
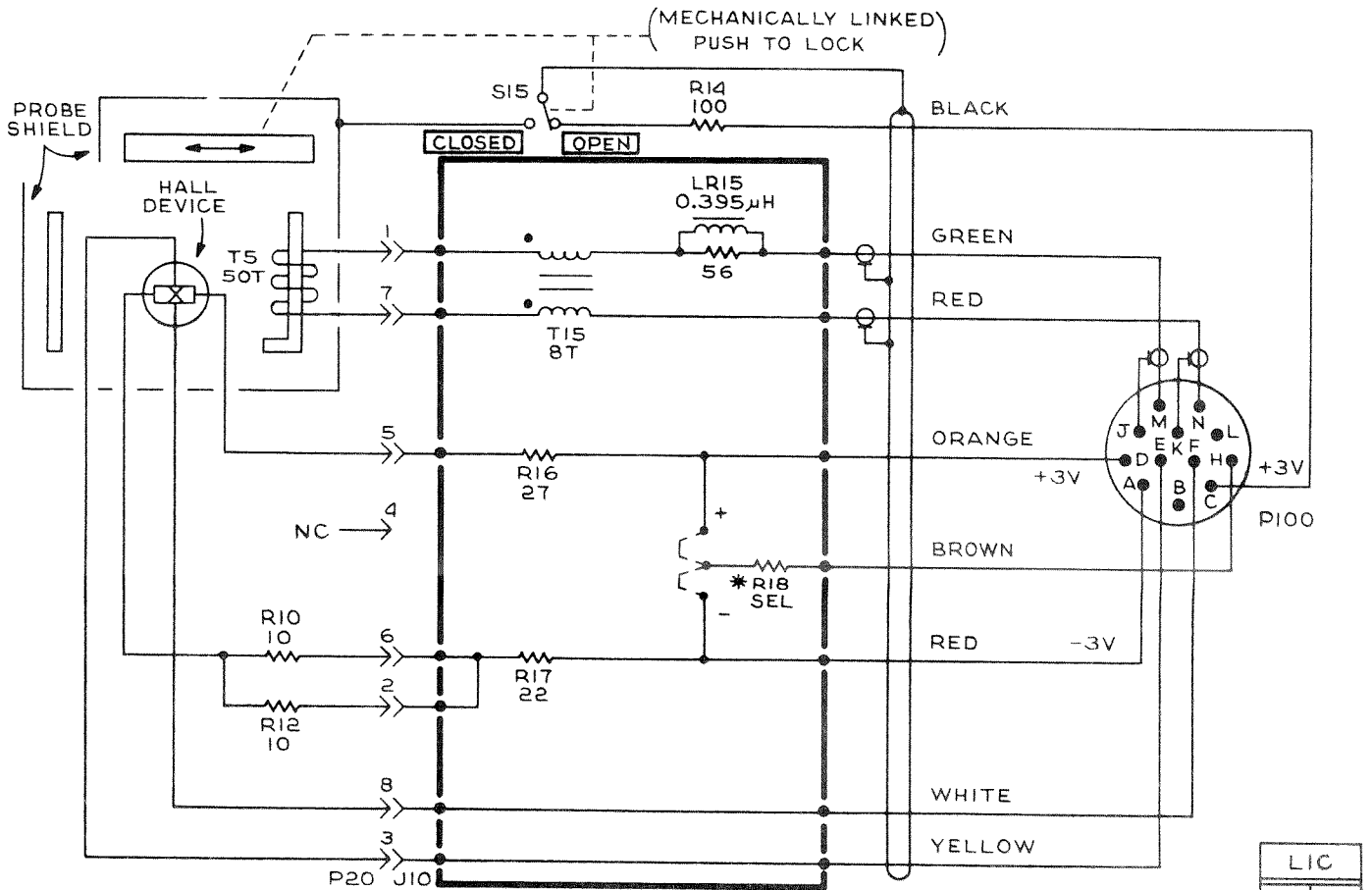
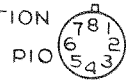

Fig. 3



NOTES:

1. * R18 IS SELECTED WITH THE STRAP EITHER TO THE ORANGE OR RED LEAD.
2. P10 IS COUNTED IN A CW DIRECTION STARTING AT THE KEY.



P6302

@

P6302 Current Probe

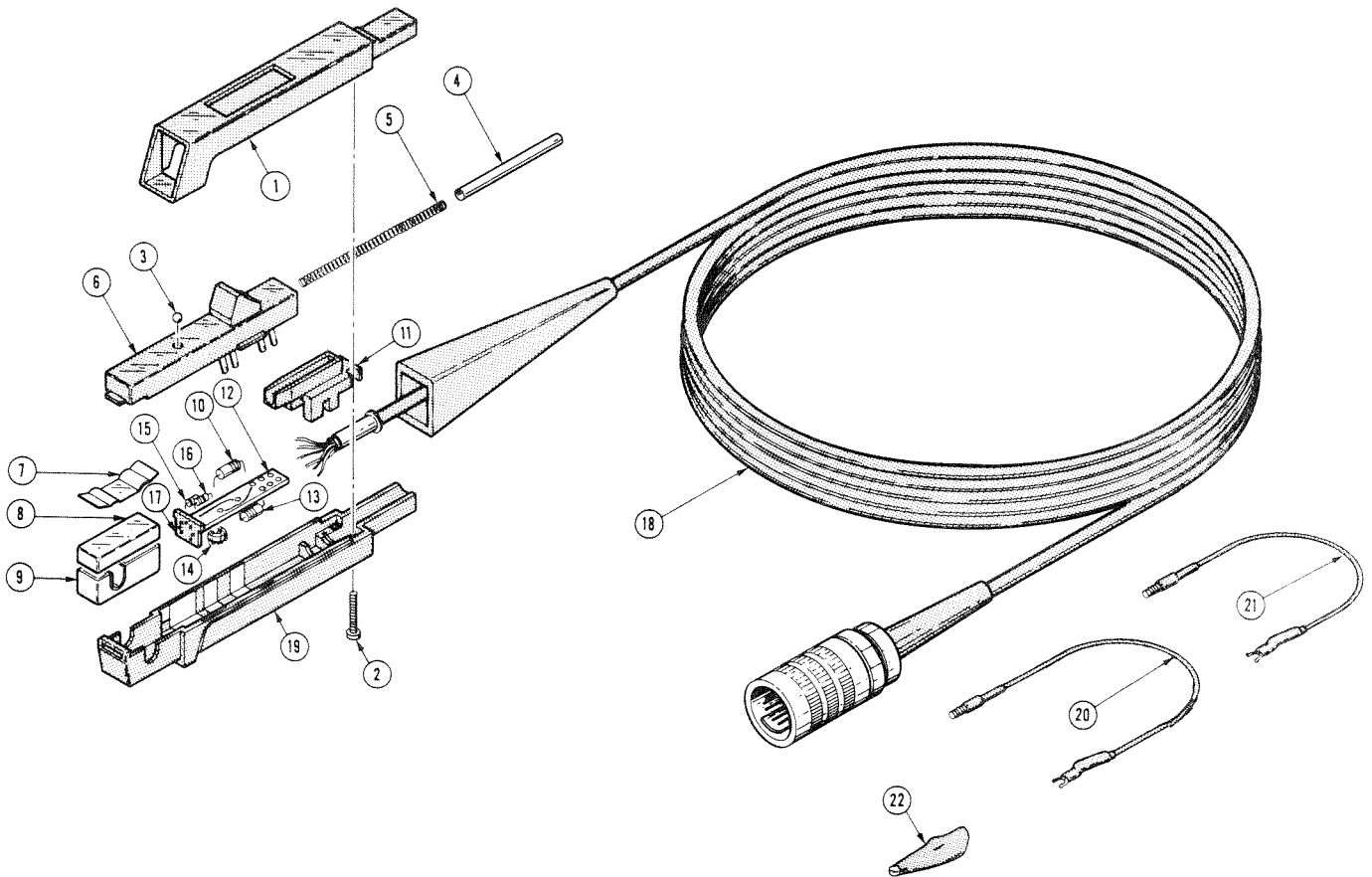

REPLACEABLE PARTS LIST

Fig. & Index No.	Tektronix Part No.	Serial/Model No. Eff	Dscont	Qty	1	2	3	4	5	Name & Description	Mfr Code	Mfr Part Number
	010-6302-01			1						PROBE,CURRENT:20 AMP,2 METER L,W/ACCESS	80009	010-6302-01
	-----			1						PROBE,CURRENT:20 AMP,2 METER LONG		
-1	204-0288-00			1						BODY HALF,PROBE:TOP (ATTACHING PARTS)	80009	204-0288-00
-2	213-0087-00			2						SCREW,TPG,TC:2-32 X 0.500 L,PNH STL	83385	OBD
-3	214-0997-00			1						BALL,BEARING:0.094 OD,SST	80009	214-0997-00
-4	214-0849-00			1						RTRN,RTN SPR:0.132ID X 0.160OD X 1.770 L,BR		
-5	214-0835-00			1						SPRING,HLCPS:0.12 OD X 2.625 L	80009	214-0835-00
-6	351-0121-00			1						CONT ASSY,ELEC:LIGHT GRAY,PLASTIC	80009	351-0121-00
-7	214-0854-00			1						CONTACT,ELEC:0.340 W X 1.0 L	80009	214-0854-00
	120-0464-02			1						TRANSFORMER,CUR:UPPER AND LOWER	80009	120-0464-02
-8	----- ¹			1						XFMR SUBASSY,CU:UPPER		
-9	----- ¹			1						XFMR SUBASSY,CU:LOW		
	----- ¹			1						RES,FXD,CMPSN:10 OHM,5%,0.125W(R10,R12)		
-10	----- ¹			1						RESISTOR SELECTED:(R18)		
-11	352-0106-00			1						HOLDER,SPR TRNR:BLACK,ACETAL RESIN	80009	352-0106-00
	317-0101-00			1						RES.,FXD,CMPSN:100 OHM,5%,0.125W(R14)	01121	BB1015
	175-1836-01			1						CA ASSY,SP,ELEC:W/CIRCUIT CARD	80009	175-1836-01
-12	670-4647-00			1						CKT CARD ASSY:	80009	670-4647-00
-13	108-0330-00			1						COIL,RF:0.4UH(LR15)	80009	108-0330-00
-14	120-0741-00			1						XFMR,TOROID:8 TURNS(T15)	80009	120-0741-00
	136-0252-00			7						CONTACT,ELEC:0.145 INCH LONG	00779	2-330808-7
-15	317-0220-00			1						RES.,FXD,CMPSN:22 OHM,5%,0.125W(R17)	01121	BB2205
-16	317-0270-00			1						RES.,FXD,CMPSN:27 OHM,5%,0.125W(R16)	01121	BB2705
-17	352-0287-00			1						HOLDER,CKT CARD:	80009	352-0287-00
-18	175-1836-00			1						CA ASSY,SP,ELEC:6.30 AWG/2,50 OHM COAX	80009	175-1836-00
-19	204-0714-00			1						BODY HALF,PROBE:W/CONTACTS,GROUND,BOTTOM	80009	204-0714-00

¹Available under 120-0464-02 only.

Fig. & Index No.	Tektronix Part No.	Serial/Model No. Eff Dscont	Qty	1	2	3	4	5	Name & Description	Mfr Code	Mfr Part Number
STANDARD ACCESSORIES											
	062-2322-00		1						DATA SHEET:P6302		
-20	175-0124-01		1						LEAD,ELECTRICAL:PROBE GND,5 INCHES LONG	80009	175-0124-01
-21	175-0263-01		1						LEAD,ELECTRICAL:PROBE GND,3 INCHES LONG	80009	175-0263-01
-22	344-0046-00		2						CLIP,ELECTRICAL:ALLIGATOR TYPE,W/COVER	80009	344-0046-00

CROSS INDEX—MFR. CODE NUMBER TO MANUFACTURER

Mfr. Code	Manufacturer	Address	City. State. Zip
00779	AMP, INC.	P O BOX 3608	HARRISBURG, PA 17105
01121	ALLEN-BRADLEY COMPANY	1201 2ND STREET SOUTH	MILWAUKEE, WI 53204
80009	TEKTRONIX, INC.	P. O. BOX 500	BEAVERTON, OR 97077
83385	CENTRAL SCREW CO.	2530 CRESCENT DR.	BROADVIEW, IL 60153

